

Sponsored by IEEE Central Illinois Section

Radio Frequency Identification:

The Supply Chain and Production Planning Case

Diego Klabjan, Department of Mechanical and Industrial Engineering



UNIVERSITY OF ILLINOIS

AT URBANA-CHAMPAIGN

The Supply Chain

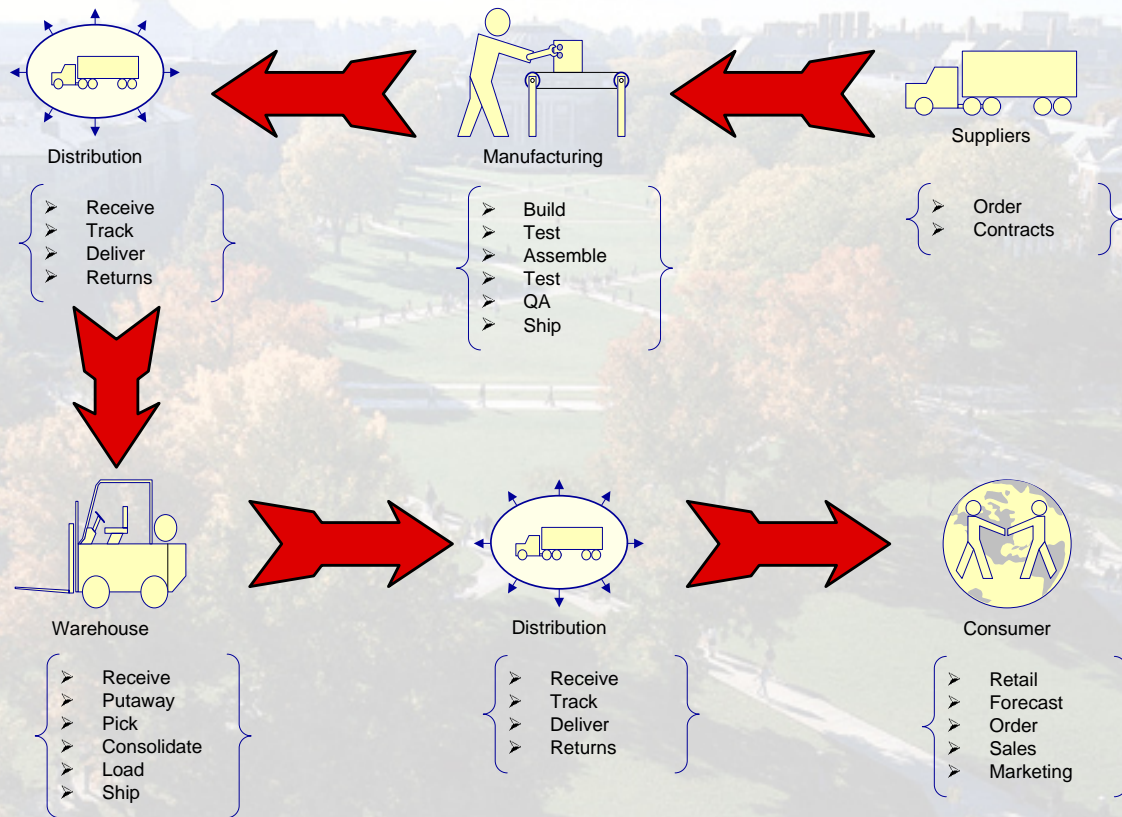

Expertise: Inventory Control

- How much inventory to keep?
- When to reorder?
- How much to reorder?
- What is the service level?
- How much safety stock to keep?
- Multi-echelon system



Expertise: Logistics

- FT vs. LTL
- Transportation mode
- 3PL or in-house
- When to ship?
- How much to ship?
- Which route?

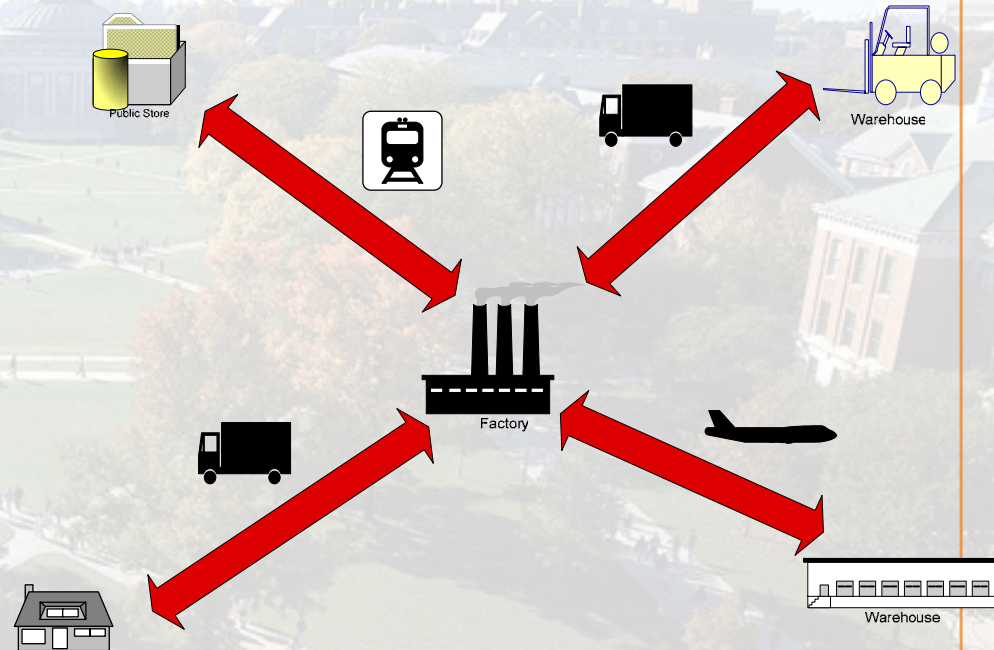

Expertise: Production Planning

- Lot-sizes
 - How many batches to produce in each period?
 - Size of each batch
- Machine scheduling
- Facility layout

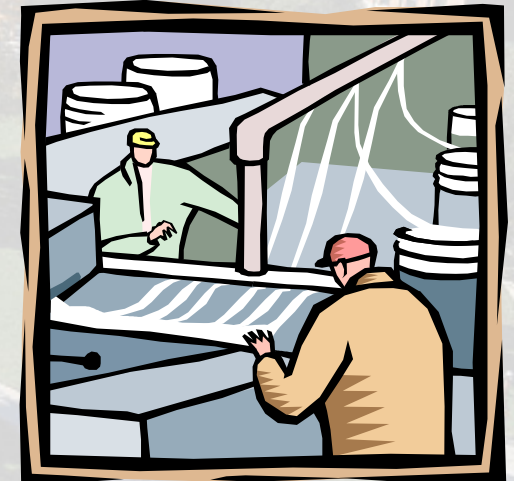

Expertise: Marketing

- Forecasting
- Quantitative marketing
 - Purchasing patterns/correlations
 - Market baskets
 - Promotions decisions
 - When to promote?
 - How to tie it to the supply chain?



Collaborators

- United Airlines
- Sabre Holdings
- FedEx Express
- Sembcomp Logistics
- Intel



Collaborations

- Research
- Consulting
- Companies
 - Large corporations
 - Smaller local companies
 - Consulting
 - Senior design project



Radio Frequency Identification

Basic Concepts

- Electronic barcode label
- Chip/tag instead of 'paper label'
- Reader reads and writes to a tag
- Communication via radio waves
- Host computer linked to a database system communicates with a reader



RFID Basic Components

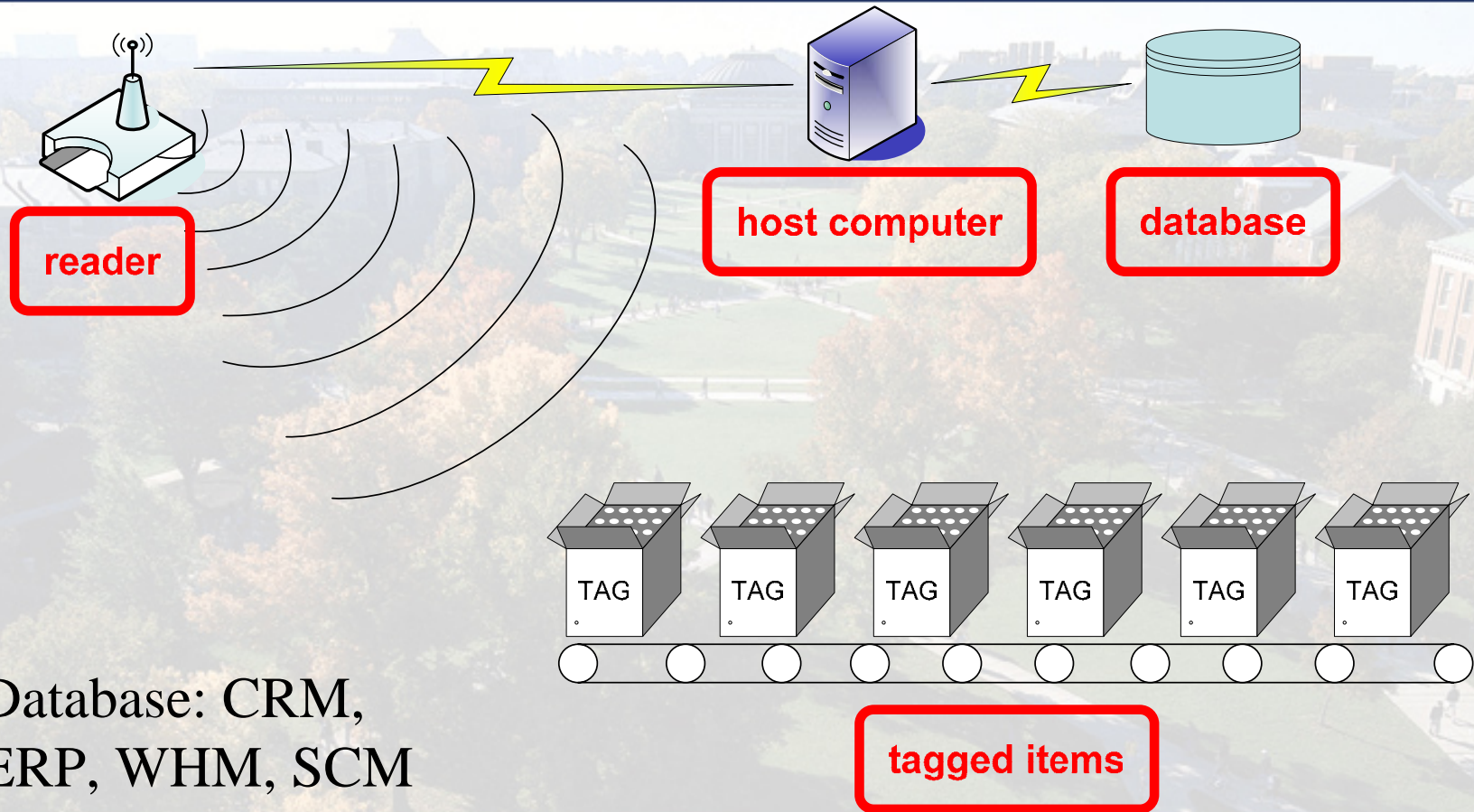

Database: CRM,
ERP, WHM, SCM



Tags and Readers

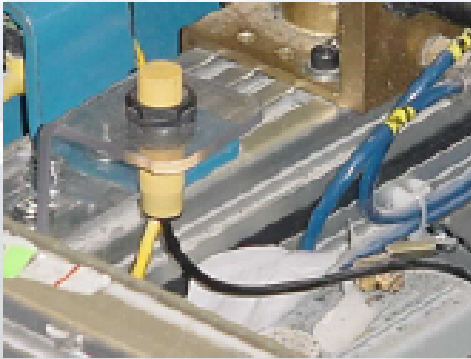

UNIVERSITY OF ILLINOIS AT URBANA-CHAMPAIGN

www.uiuc.edu

Radio Frequency Identification

- Dates back 30 years
- Why such a buzz now?
 - Wal-Mart initiative for their 100 top suppliers
 - All pallets to three Texas distribution centers must be RFID tagged
 - Department of Defense
 - All supply must be RFID enabled



Main Difference

- Wal-Mart does not cover cost
 - No selling price increase
- DoD covers extra cost as part of the contract
- Many supply to both customers



Tag Architecture

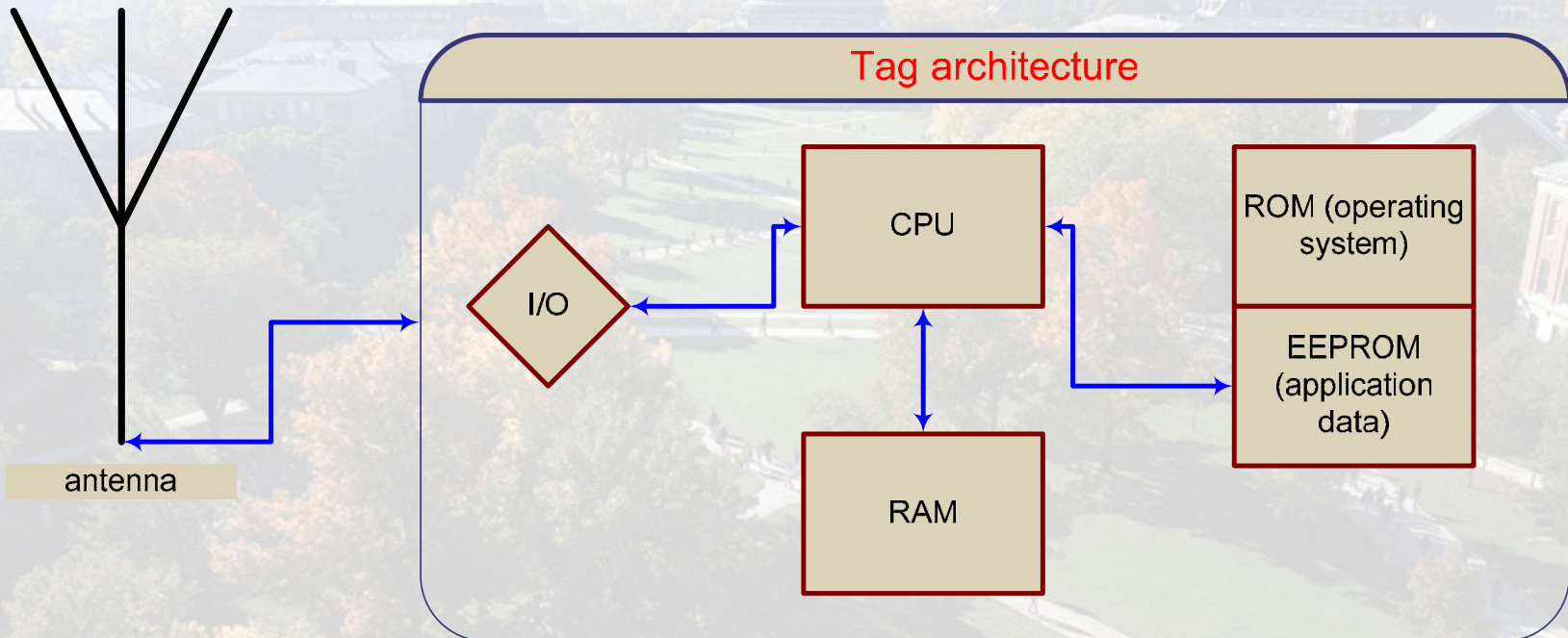

Tags

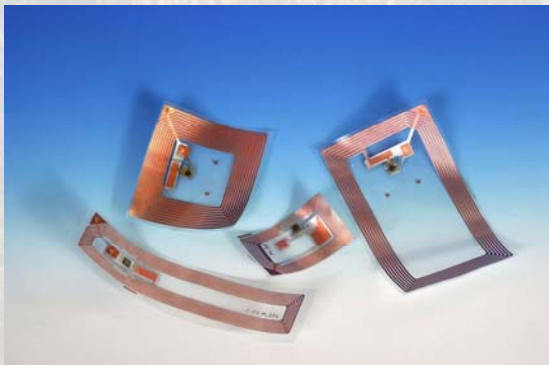
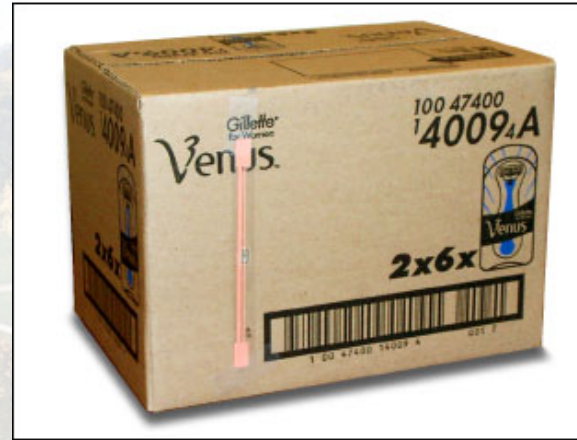

UNIVERSITY OF ILLINOIS AT URBANA-CHAMPAIGN

www.uiuc.edu

Tag Types

- Read range
 - 20 inches to 20 feet
- Power
 - Active
 - Pasive
- Read/write



Read Ranges

	Frequency	Read range
LF	100-500 kHz	Up to 20 inches
HF	13.56 kHz	Up to 3 feet
UHF	866-956 MHz	Up to 20 feet
Microwave	2.45 GHz	3 to 10 feet



Active Tags

- Self powered
 - Battery
- Larger and more expensive
- Longer read range
- Sends out signals “Here I am”



Passive Tags

- No power
 - Powered by readers
- Reader polls
- Reacts (wakes up) to electromagnetic fields



Modes

- Serial or Read-only
 - Preprogrammed by the manufacturer
- Write Once - Read Many (WORM)
- Write and add information
- Write and overwrite



First Main Advantage

- No need for line of sight
 - Communication via air
- Not the case for barcode scanning



Electronic Product Code

- A numbering scheme that uniquely identifies each item
- A connection between physical objects (tags) and a computer
- Store only relevant information on a tag and link this tag with a database



EPC

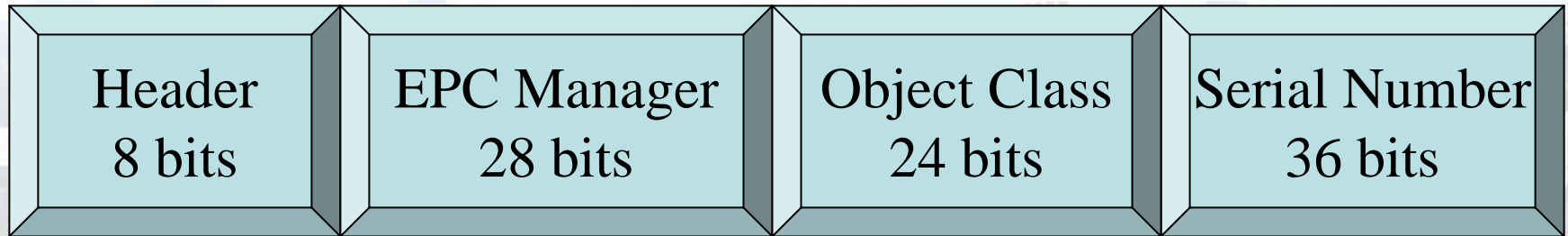

- Code version number
- Organizational entity (company, city)
- Type of product (SKU, road signs)
- Unique item identifier



EPC

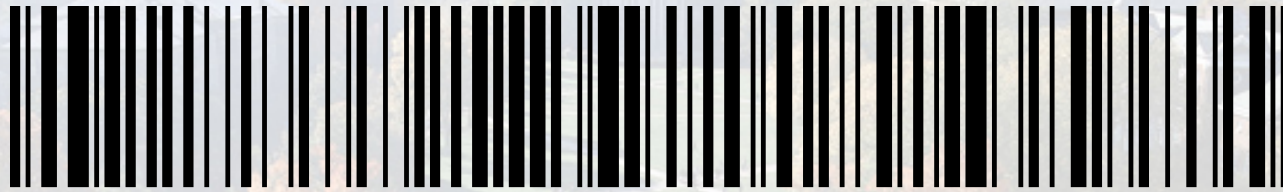

(01)

1

0614141

00235

8

(21) 8674734

header

organization

object

serial number



UNIVERSITY OF ILLINOIS AT URBANA-CHAMPAIGN

www.uiuc.edu

EPC Global Network

- Object Naming Service (ONS)
 - Equivalent to DNS for web pages
 - Contract won by VeriSign
- Link EPC numbers to database
- Physical Markup Language (PML)
 - Equivalent to XML
 - Additional information (expiry date, etc)



ONS/PML

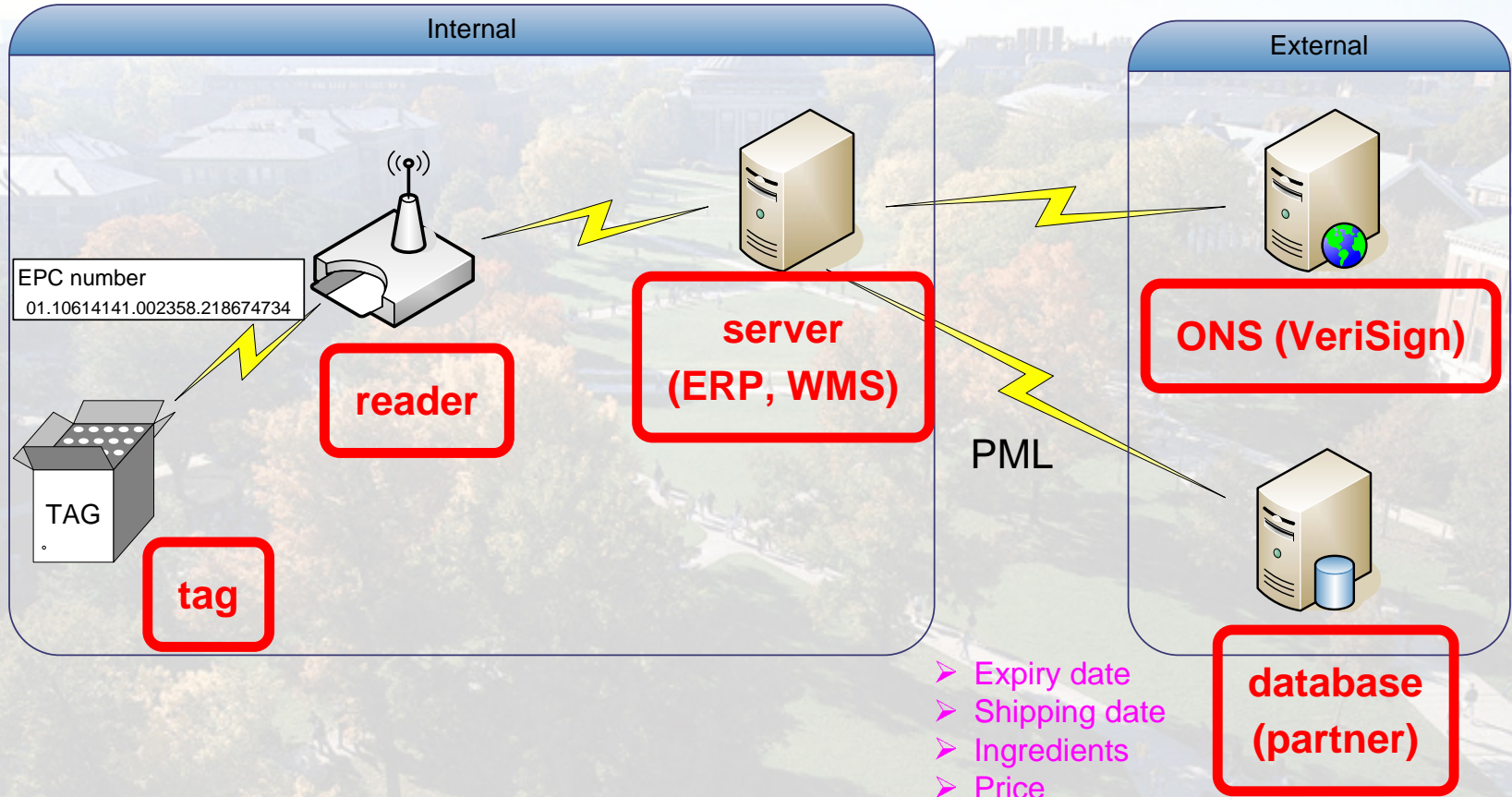

EPC vs. UPC

- Item level tracking
- Coexistence
- Smart labels
 - Barcode label
 - RFID tag

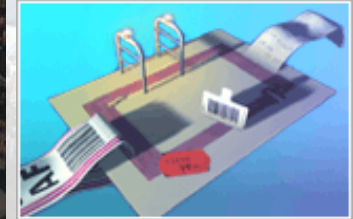

Second Main Advantage

- Item level tracking
 - Recalls
 - Counterfeiting
- Enabled by 96-bit EPC coding scheme



Applications

- Asset tracking
- Warehousing
- Counterfeiting
- Recalls
- Retail
- Production/assembly lines
- Baggage tracking



Warehousing

- Tagged pallets and cases come in
- Check accuracy of the order
- Putaway by forklifts equipped with readers
- Picking more accurate
- Check orders
- Place ASN



Benefits

- Inventory accuracy
 - Receiving
 - Orders
- Labor cost savings



Retail

- Smart shelves
 - Every shelf has a reader
- Reduced out-of-stocks
 - Greater visibility for suppliers
- Visibility in the store
- Automated inventory count
- Merchandise quality (expiration date)



Future Grocery

- Metro group
 - Item level tagging at a grocery store in Germany
- Prototype store

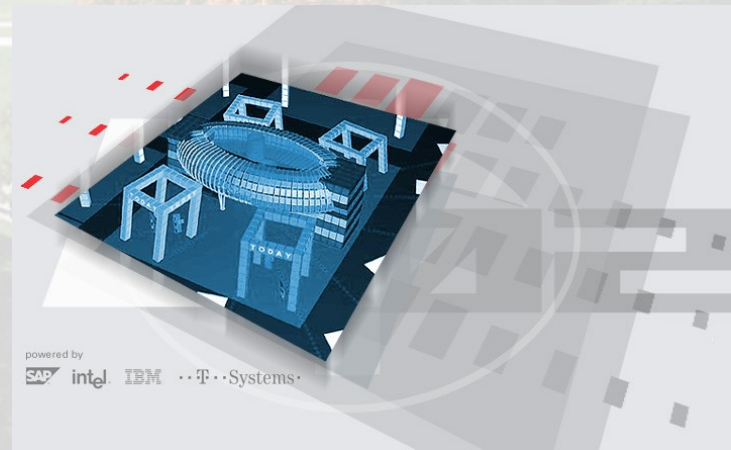

Slap and Ship

- Many suppliers to Wal-Mart use slap and ship
 - Slap the RFID tag just before shipping
- Suppliers incur only extra cost
- What about the added value if implemented earlier in the supply chain?



Summary

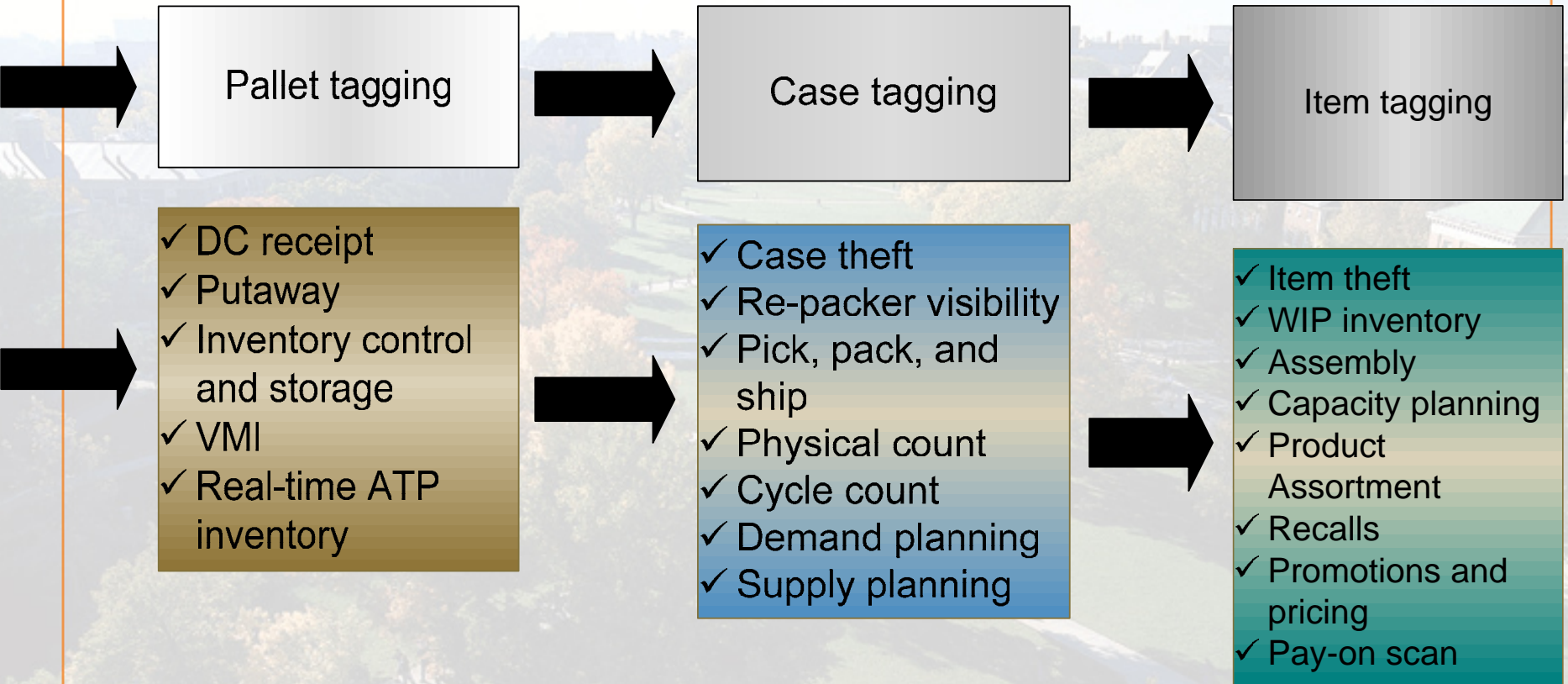

Successful Implementations

- Purdue Pharma: private pharmaceutical company
- Wal-Mart supplier
- Item level tagging of an entire packaging/production line
 - Main objective counterfeiting
- Smart label approach



Purdue Pharma

- Defect rate very low
 - Defective tags
 - Requires several read/write operations
 - Almost 100% read rate
 - QA checks RFID samples
- Long term ROI
- Expand to other lines



Successful Implementation

- Procter & Gamble manufacturing plant in Spain
- Order loading at docks
 - Put pallets assigned to a truck on a location and then load them
 - Put pallets directly on a truck
 - Must be accurate since shipped directly to customers



Procter & Gamble

- Options
 - Tags on pallets (too expensive)
 - Tags on fork lifts, readers at docks (too expensive)
 - Tags in the floor, each fork lift has a reader

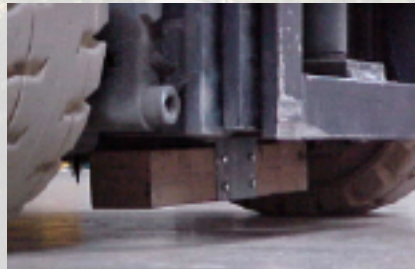

Procter & Gamble

- Principle
 - Each pallet assigned to a fork lift
 - Each fork lift to a dock
 - As the fork lift passes over a tag, the fork lift is checked versus the dock
- ROI
 - \$100,000 to implement
 - 40% higher throughput



Successful Implementation

- Johnson Controls: car and truck seats
- JIT; 1,500 seats daily
- Clipboards at each production station
 - Human error
- 14 production stations
- Orders specify quantity and exact loading sequence



Johnson Controls

- On the production line seats on a metal pallet
- Tags assigned to models
 - Read only tags
 - Encodes a production sequence
 - \$15 per tag



Johnson Controls

- Pallet loaded with a seat passes over a reader
- Via central computer, the operations at this station are transmitted
- After production line, loaded to read/write tagged pallets



Johnson Controls

- Pallet tags read before loaded to an outbound truck
- 99.9% accuracy



Not so Successful Implementation

- Prada store in New York City
- Every store item is tagged
- Objective to improve service (customer experience)
- Dressing rooms equipped with readers
 - Display information on the dress (color, fabric, materials)
 - Related lines and looks



Prada Store

- Handheld readers on shelves
 - Salespeople scan tags
 - Information shows on a display
 - Related lines, colors, models



Prada Store

- Tied to real-time inventory in the back room
 - Is different color suit in the back room?
- Tie to online shopping via loyalty cards
 - Whatever is tried, it is recorded
 - Personalized marketing
- \$1 per tag



Prada Store

- Not so successful
- Salespeople have not been trained
- They do not use handheld readers
- Additional cost of recurrent training
 - Training of new employees



Implementation Hurdles

- Tag placement
 - Tag orientation matters (reading)
 - Metal and water interference
- Reader placement
 - Reading range
 - Faulty reads and writes
 - Parallel to tag



ROI

- Tag cost 20-50 cents
- Readers a few thousand dollars
- Widespread case level adoption when tag below 5 cents
- Shipping 4.5 million cases to Wal-Mart
 - Implementation cost of 9 million dollars
 - Over 7 million dollars for tags



What if?

- What if implemented earlier?
 - Improved accuracy
 - Manpower savings
 - Decreased stock-outs
- These benefits quickly outweigh the cost
- Slap and ship only short term strategy



Current RFID Research

- One-to-one in-store marketing
- Which coupons to give to a customer during the shopping experience?
- RFID component
 - Knowledge of what is in the cart
 - If bought beer, give coupon for pretzels
- Route the consumer to promotion sites



Shopping Experience

7 1/2"

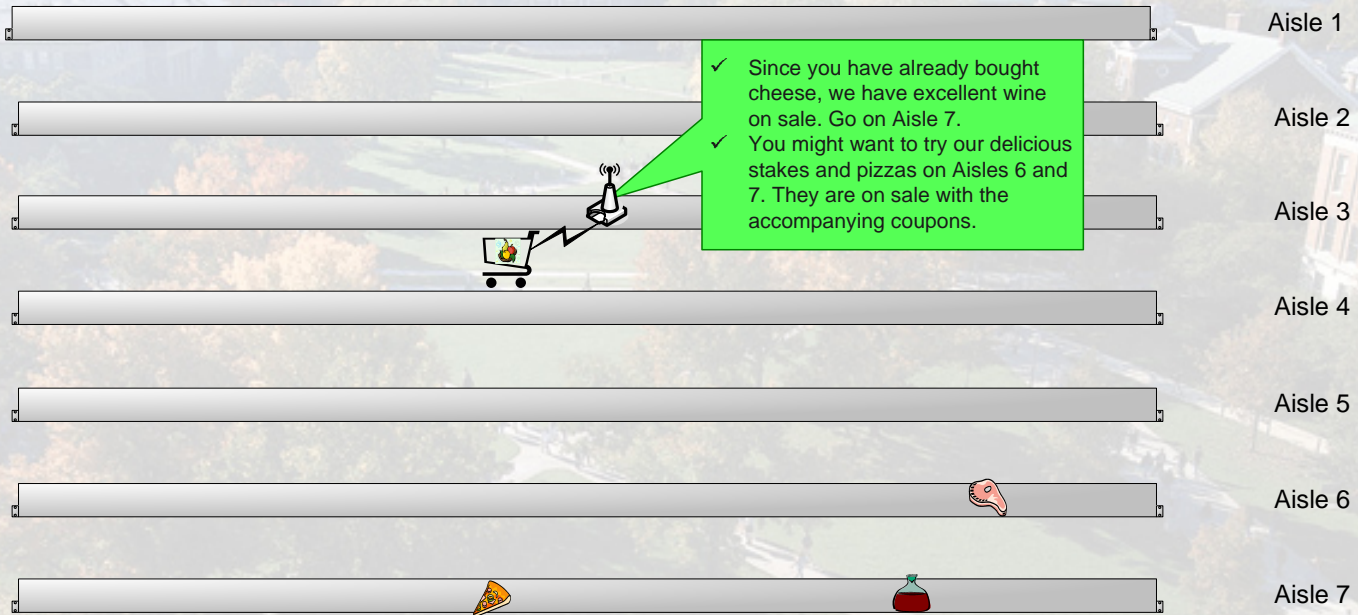

Shopping Experience

7 1/2"



Shopping Experience

7 1/2"



A Step Further: Dynamic Pricing

That's too expensive.



Mr. Klabjan, you haven't bought a beer in a month. Would you like to buy one for \$1.49?



A Step Further in Dynamic Pricing

What about a pack for 6 x \$1.20?

Mr. Klabjan, being a valuable customer we have a special price of \$1.29.



A Step Further: Dynamic Pricing

Excellent. I'm looking forward to Illini basketball.



Mr. Klabjan, you got yourself a deal.



Item Level Pricing

- Consider soda
 - Warm soda on shelves
 - Cold soda in refrigerator
- Every bottle has a tag
- We can assign different price based on this added value
- We can maintain the same SKU



Item Level Pricing

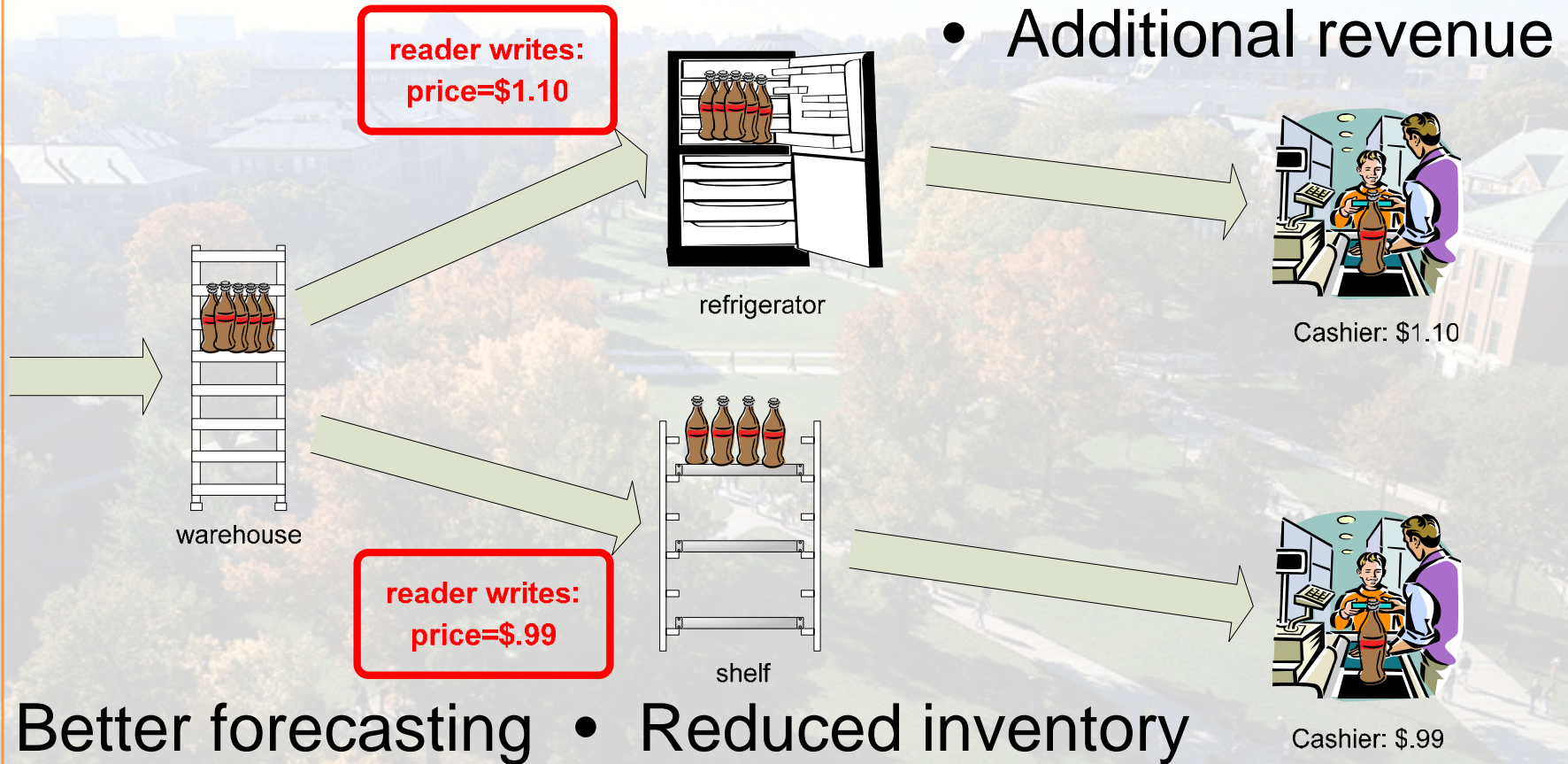

Cross Docking

- Pioneered and mastered by Wal-Mart
- Bring supply to a DC, consolidate, and immediately ship out
- No or very little inventory

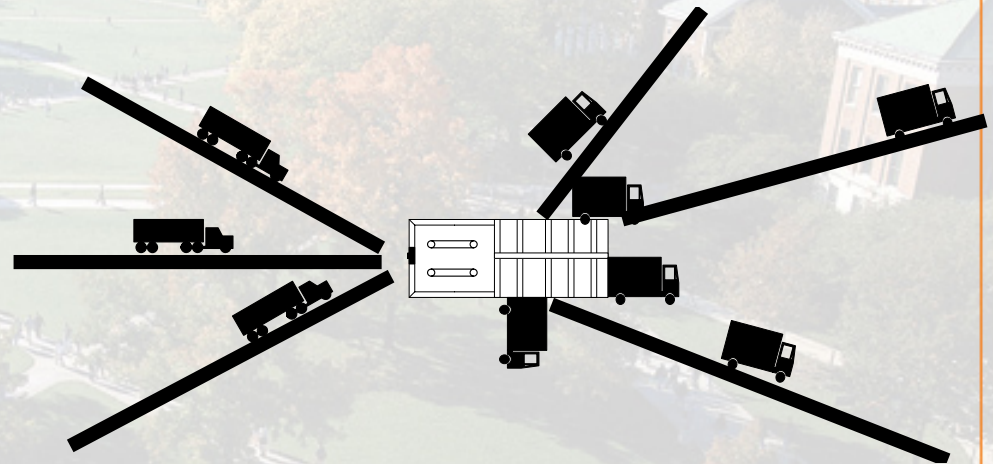

Cross Docking

- RFID brings complete visibility
- Improved execution/disruption management
 - Late inbound conveyance
 - Should the corresponding outbound conveyance wait?
- Knowledge of the sorting process
 - Where are the items for this conveyance in the sorting process?



RFID vs. Barcodes

- Not a technology to replace barcodes
- Coexistence
- Enhancement to barcodes with several additional features
 - No line of sight
 - Item level identification



Other Applications

- Secure access to rooms, buildings, etc.
- Ski resorts and ski passes
- Toll booths
- Animal tracking



Other Issues

- Privacy
 - Benetton had privacy issues
 - Kill the tag or remove it
 - Current take by the policy maker: Use your own judgment
- Collision avoidance used in readers
- Reader commands



Thank you for your attention!



UNIVERSITY OF ILLINOIS AT URBANA-CHAMPAIGN

www.uiuc.edu